



Global Forum 2003  
Infrastructures and Services  
Strategies for success



## The new Danish business portal: *an example of Government on demand*

Giorgio Prister  
EMEA Sales Executive  
Local Government and Health  
Rome, November 7, 2003

# IBM's Vision: The 'on demand' era



## The Virk initiative: Political goals

---

- "The administrative burdens of businesses must be reduced by 25% before year 2010."
- "The businesses should have one business portal that holds all public information and services but also a wide set of private services."
- "The businesses should experience the public sector as one partner that acts coordinated and is capable to work in a public/private integrated model."

*The Danish Government*

The foundation of VIRK is to be *the* focal point between the individual decision maker in the small-medium sized businesses (SMB's) and it's public and private partners.

**- Traditional dialogue -**

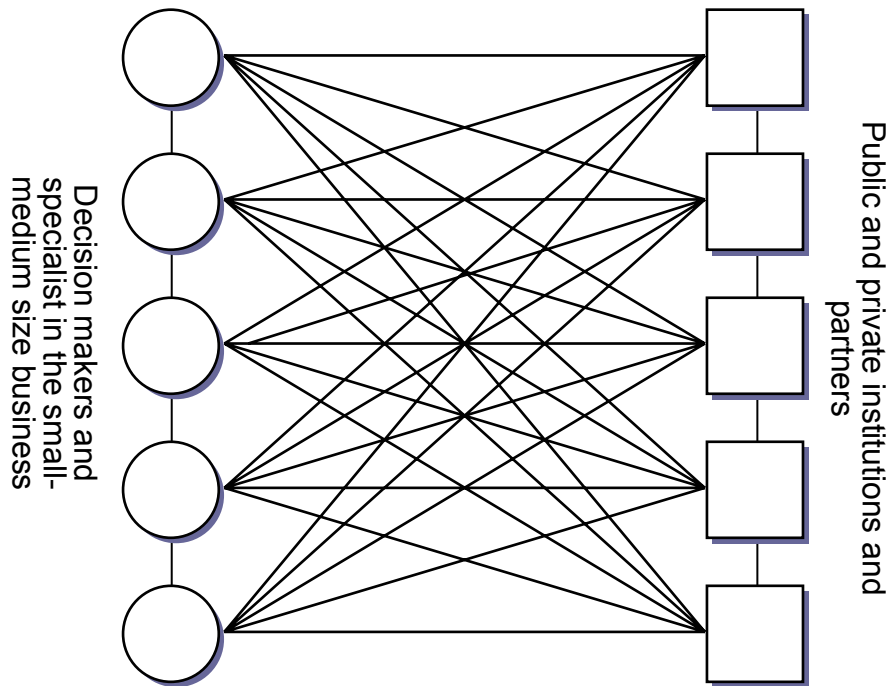

**- Portal dialogue -**

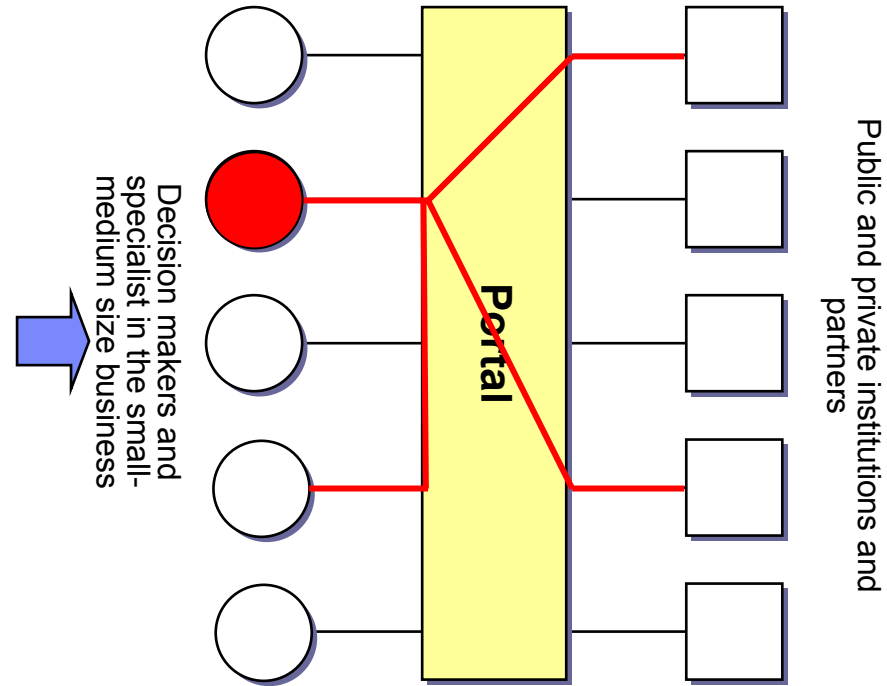

# VIRK is a complex project based on public-private partnership and with many partners and stakeholders

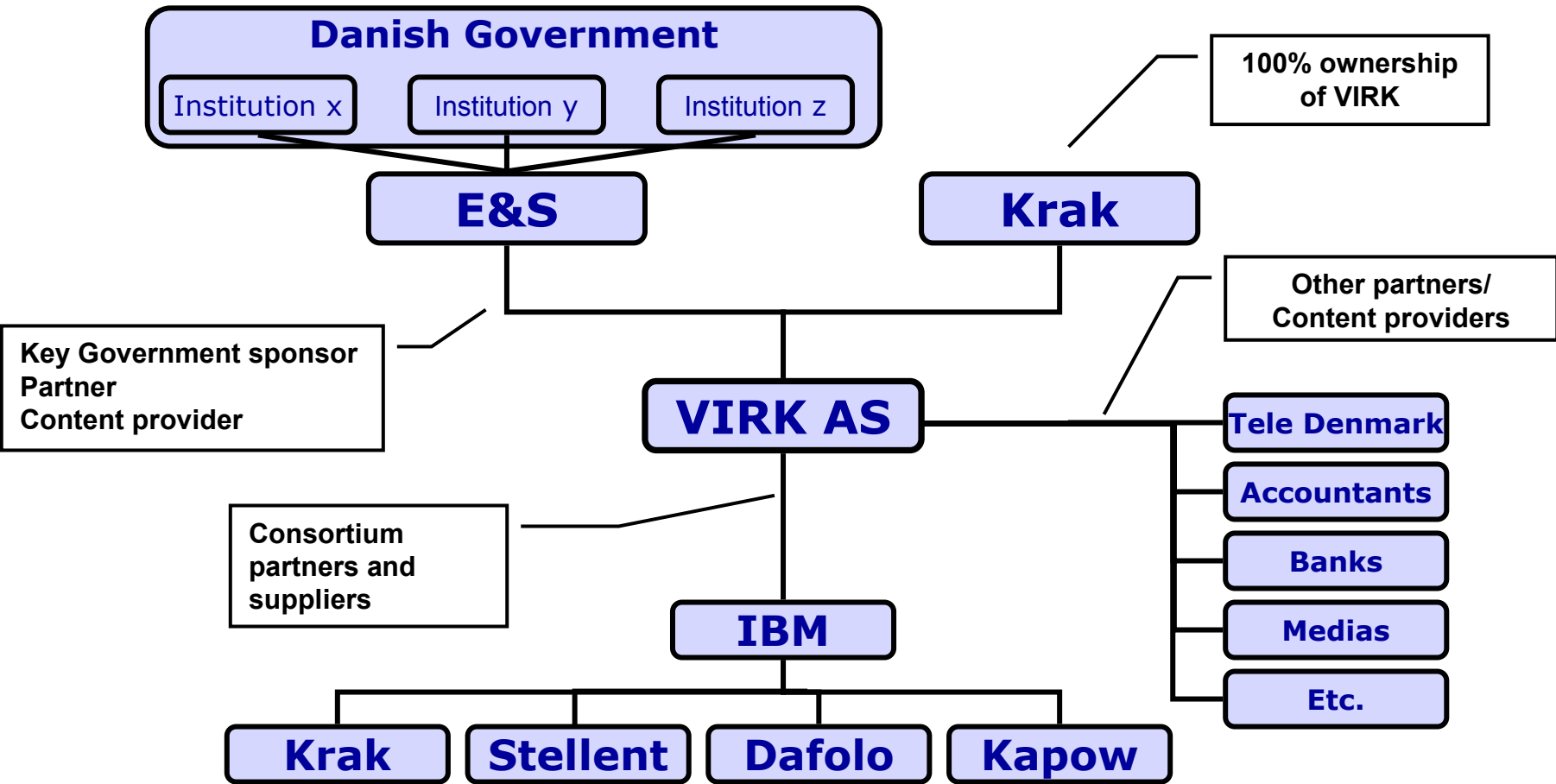

# VIRK is the electronic virtual desktop of the individual user

---

## Personal



- Calendar, mail, inspiration, tools, career information, education etc.

## Business

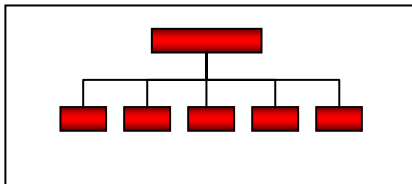

- Sales, Marketing, Production, Buy and Supply, Finance, Management etc.

## Surroundings



- News, Market information, Marketplaces, Knowledge networks etc.

## Vision: VIRK in may 2005...

---



"Any business  
has a bank account, an accountant  
and virk.dk!"

- VIRK is the preferred source to business related information and services
- VIRK is the preferred partner for distribution (and development) and business related services

# Virk go-to-market model

## Focus is

- People in their professional job role (primary)
- Line of business (secondary)

## Areas of business and services:

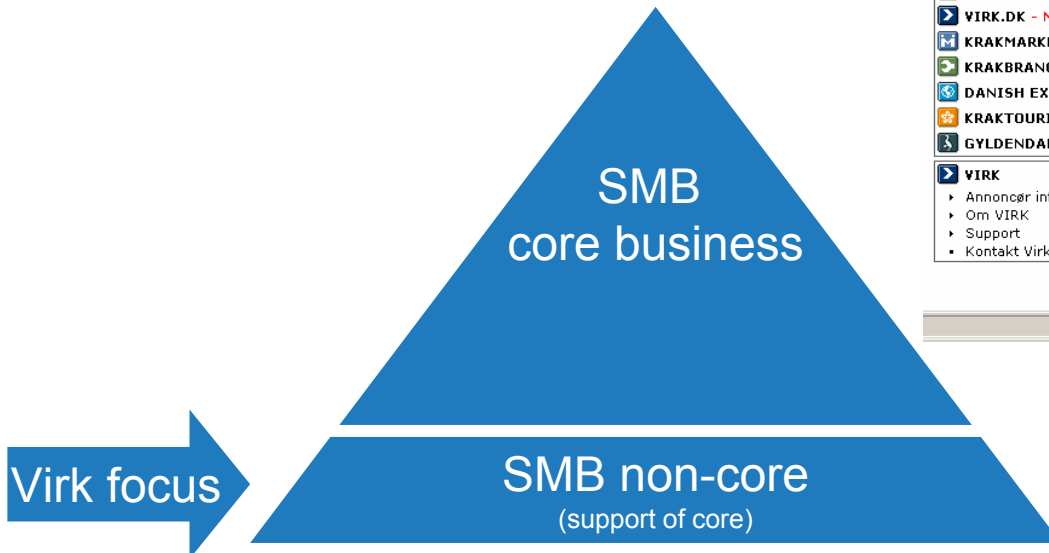



# The main Government sponsor is The Danish Commerce and Companies Agency (EogS)



The Danish Commerce and Companies Agency (DCCA) is an agency under The Danish Ministry of Economic and Business Affairs.

The agency acts on behalf of the whole central government and the central cross agency e-government taskforce!

The day-to-day responsibilities and activities of the agency take place within three main areas:

- The administration of company and enterprise legislation.
- The registration and disclosure of certain information and documents about companies, including company accounts.
- Improving the conditions of the business community.

In all three areas the agency is involved in work at international level

“...It is of strongest importance that the portal lessens the administrative burden for companies. Companies should focus on growth and not on reporting to the public institutions...”

(Quote from the Danish Vice Prime Minister)

## The main contract holder is Krak who 100% owns the newly formed portal company VIRK.

---



Krak is a well founded Danish information and service company with documented success in running business portals in Denmark.

Krak is running the biggest business portal in Denmark with more than 1.3 million hits per day and almost 700 thousand unique users per week.

The Krak brand is very solid and well known in the business to business marketplace.

Krak has deep knowledge of the Danish businesses and many years experience in bringing value add service to this market segment.

## IBM is the main technology supplier with a number of partners.

---

IBM is responsible for designing, building, implementing and hosting of the portal together with the following main partners:

- Content is categorized and managed by use of Stellent Content Management System.
- Content will be captured using the unique technology from Kapow Technologies.
- The advanced e-form environment is delivered by Dafolo.
- The personalization data and front-end is delivered by Krak Solutions

**STELLENT™**  
BUSINESS CONTENT MANAGEMENT

 **kapow**

 **Dafolo**



## The portal consist of four major elements...

---

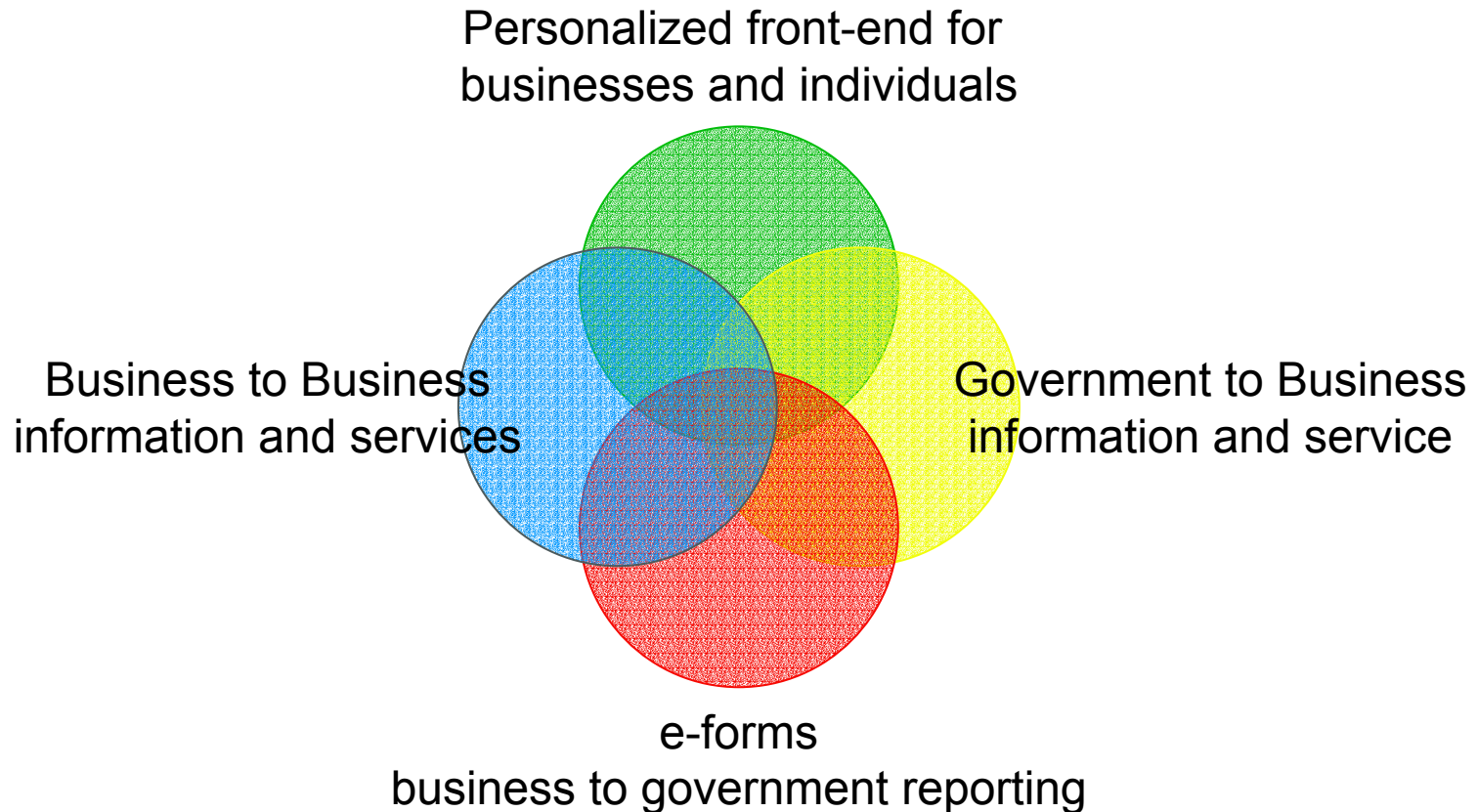



Virk.dk er et samarbejde mellem Krak og staten.  
IBM er leverandør af teknologi og drift.



Menu

VIRK.DK > Forside

VIRK.DK

- **Forside**
- ▶ Økonomi
- ▶ Personale og Løn
- ▶ Ledelse og Strategi
- ▶ Indkøb og Logistik
- ▶ Salg og Markedsføring
- ▶ IT
- ▶ Brancher
- Indberetninger
- ▶ VIRKviser

Portaler

- KRAK.DK**
- KRAKGULE**
- VIRK.DK - NY!**
- KRAKMARKED**
- KRAKBRANCHER**
- DANISH EXPORTERS**
- KRAKTOURIST - NY!**
- GYLDENDALS LEKSIKON**

VIRK

- ▶ Annoncør info
- ▶ Om VIRK
- ▶ Support
- Kontakt Virk.dk



Velkommen til Virk.dk

Virk.dk samler trådene for danskere på arbejde.

- ▶ [Om Virk.dk](#)
- ▶ [Bliv registreret bruger](#)
- ▶ [Navigation](#)
- ▶ [Sikkerhed på Virk.dk](#)

Søgeord:

Søg

- Hele Virk.dk
- Kun Indberetninger & Services
- ▶ [Avanceret søgning](#)
- ▶ [Få hjælp til søgning](#)

**SYGEDAGPENGE**

Anmeld fravær online med  
[VIRKviser:sygedagpenge](#)

**TRANSPORT**

Virk.dk viser vejen for folk på  
farten og deres hjælpere.

▶ [Transport](#)

**TEMAER**

- ▶ [Skat, moms og afgifter](#)
- ▶ [Ansæt ny medarbejder](#)
- ▶ [Start af ny virksomhed](#)
- ▶ [Eksportfinansiering](#)
- ▶ [Ledelse i praksis](#)
- ▶ [Arbejds miljø](#)
- ▶ [Find vej i tilskudsjunglen](#)
- ▶ [Offentlige indberetninger](#)

**KrakMarked**- Find produkt:

▶ [Avanceret søgning](#)

Søg

**Søg på Krak**- Find navn, tlf.:

Firma

Person

Offentlig

**Brancher: Udvalgte informationer og services**

- ▶ [Advokater](#)
- ▶ [Grafisk Branche](#)
- ▶ [Maskin & Metal](#)
- ▶ [Autobranchen](#)
- ▶ [Hotel & Restauration](#)
- ▶ [Revisorer](#)

**Log ind**

- Ny Bruger**
- Digital Signatur**
- Indberetninger**
- Mere om Virk.dk**

Log ind

**BOGKLUBBEN**  
12 bøger

og deltag i konkurrencen om boligindretning til **25.000 kr.**

↓ ↓ ↓

**klik her**

# Convergence of Business and ICT

*Productivity*

*Governance*

*Economy*

*Capital and Asset Utilization*

*Security  
Threats*

*Pricing  
Pressures*

*Customer  
Preferences*

**Business**

***On Demand***

**Technology**

*Open Movement*

*Substitution*

*Autonomic Computing*

*Grids*

*Web Services*

*Clusters*

*Blades*

*Virtualization*

*Standards*



*an example of Government on demand*

**THANK YOU !!**

Giorgio Prister  
EMEA Sales Executive  
Local Government and Health  
Rome, November 7, 2003